



匯統國際股份有限公司
Huey Tung International Co.,

產品規格書 Specification

[Model : HTB-4113 / 2012.11.23 version]



Cara Audio Corporation

No.69, Lane 762, Dingzhong Road, Sanmin District, Kaohsiung City, Taiwan, ROC.

Tel: 886-7-310 5786 / Fax: 886-7-310 0783

E-mail: carawang@hueytung.com.tw / <http://www.hueytung.com.tw>

揚聲器製品規格書 SPEAKER SPECIFICATION

型號 Model Number: HTB-4113

項目 Items		規格 Specification		
1	公称阻抗 Nominal Impedance	8Ω±15% at 300 Hz 1.0v		
2	最低共振周波数 Lowest Resonance Frequency	90 Hz±20%Hz Without a baffle		
3	实效周波数带域 Effective Frequency Range	F0~20KHz -10dB		
4	出力音压 Output Sound Pressure Level	84dB±3dB 1W/1M at (600,800,1K,1.2K)Hz AVE.		
5	入力 Input	定格入力 Rated input 15 W	最大入力 Maximum input 30 W	
6	磁束密度 Flux Density	-----±10% GAUSS		
7	异常音试验电压 Buzz & Rattle Test	Must be normal at sine wave 10.95 V		
8	动作试验电压 Operation Test	Must be normal at program source		
9	极性 Polarity	/		
10	磁石尺寸/重量 Magnet Dimension/Weigh	Magnet:80*40*15 Sub Magnet:	/G	
11	连续负荷试验 Life Test	EIA-R426B noise 15 W 8 hours	After the Test, Speaker should be meet the Outside and item 7,8	
12	耐热试验 Heat Resistance	70°C±5°C 30%-35%RH 8Hours and then room temperature 1 hours		
13	耐湿试验 Humidity Resistance	40°C±2°C 90%-95%RH 8Hours and then room temperature 1 hours		
14	耐寒试验 Cold Resistance			
15	落下试验 Drop Test	1M 75°±2°		
16	绝缘耐压试验 Insulation Resistance	Or more 1MΩ 以上		
17	周波数特性 Frequency Response Curve	参照附图 On Other Drawing		
18	失真率 Distortion	/		
19	各部 材质	Cone Paper	Rubber Edge+PP cone	
		Voice Coil	Aluminum+SV	
		Cap	PP	
20	总重量 Total Weight	/		
	Size: 4"	Approve:	Check:	Design:
	試作發行: 2012.11.22	Arthur	John	LIU

SPL vs Freq

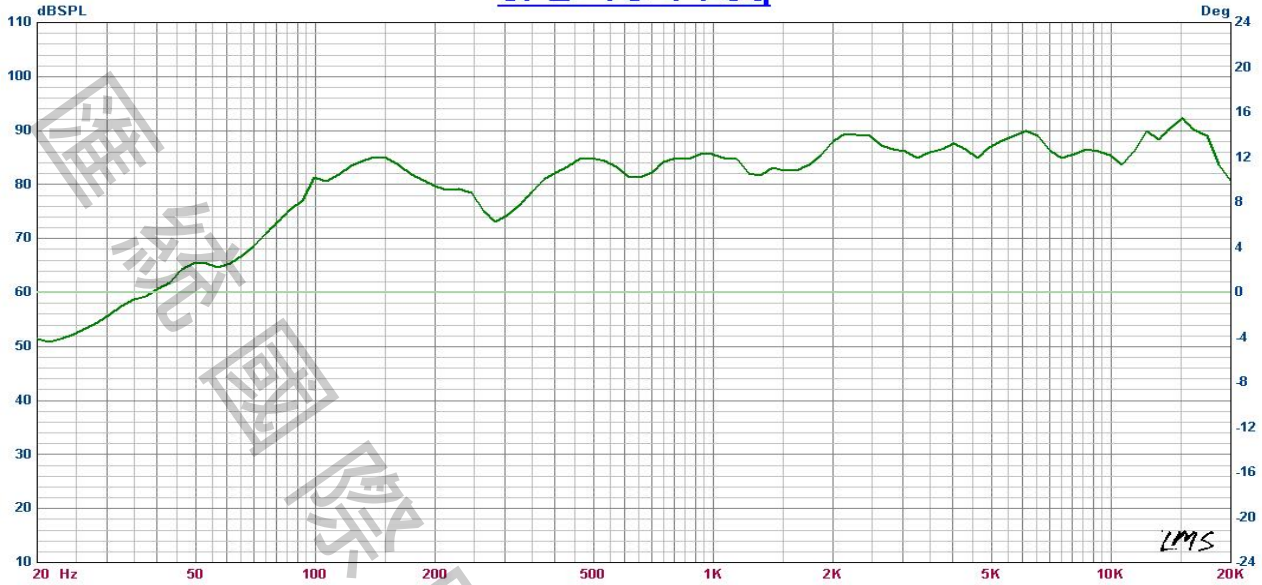

Map — 62: HTB-4113 音箱#1 1W/1M

Notes

LMS 4.5.0.351 二月-12-2005 Person: Company: Project: File: 4.lib Nov 21, 2012 Wed 4:11 pm LINEAR SYSTEMS

Impedance vs Freq



Map — 24: HTB-4113#1 音箱 IMP

Notes

LMS 4.5.0.349 十一月-14-2004 Person: Company: Project: File: SSSSS.lib Nov 21, 2012 Wed 4:04 pm LINEAR SYSTEMS

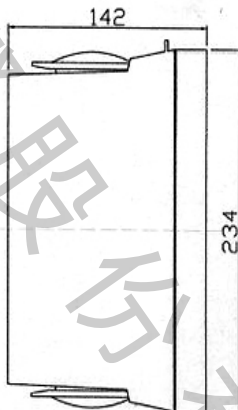
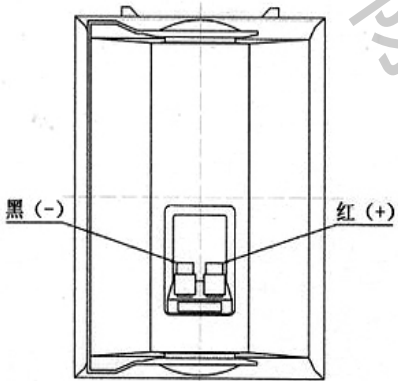
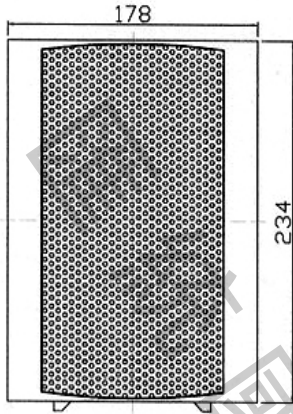

Tolerance: ± 0.5

Unit: mm