



匯統國際股份有限公司  
Huey Tung International Co.,

# 產品規格書 Specification

[ Model : HT-6353 / 2012.11.5 version ]



**Cara Audio Corporation**

No.69, Lane 762, Dingzhong Road, Sanmin District, Kaohsiung City, Taiwan, ROC.

Tel: 886-7-310 5786 / Fax: 886-7-310 0783

E-mail: [carawang@hueytung.com.tw](mailto:carawang@hueytung.com.tw) / <http://www.hueytung.com.tw>

# 揚聲器製品規格書

## SPEAKER SPECIFICATION

**型號 Model Number: HT-6353 天花喇叭帶塑膠后桶帶塑膠后桶**

項目 Items		規格 Specification		
1	公称阻抗 Nominal Impedance	8Ω±15% at 250 Hz 1.0v		
2	最低共振周波数 Lowest Resonance Frequency	140 Hz±20%Hz Without a baffle		
3	实效周波数带域 Effective Frequency Range	F0~20KHz -10dB		
4	出力音压 Output Sound Pressure Level	85dB±3dB 1W/1M at (600,800,1K,1.2K)Hz AVE.		
5	入力 Input	定格入力 Rated input 20 W	最大入力 Maximum input 40 W	
6	磁束密度 Flux Density	-----±10% GAUSS		
7	异常音试验电压 Buzz & Rattle Test	Must be normal at sine wave 12.65 V		
8	动作试验电压 Operation Test	Must be normal at program source		
9	极性 Polarity	/		
10	磁石尺寸/重量 Magnet Dimension/Weigh	Magnet:90*45*17 Sub Magnet:	/G	
11	连续负荷试验 Life Test	EIA-R426B noise 20 W 8 hours	After the Test, Speaker should be meet the Outside and item 7,8	
12	耐热试验 Heat Resistance	70°C±5°C 30%-35%RH 8Hours and then room temperature 1 hours		
13	耐湿试验 Humidity Resistance	40°C±2°C 90%-95%RH 8Hours and then room temperature 1 hours		
14	耐寒试验 Cold Resistance			
15	落下试验 Drop Test	1M 75°±2°		
16	绝缘耐压试验 Insulation Resistance	Or more 1MΩ 以上		
17	周波数特性 Frequency Response Curve	参照附图 On Other Drawing		
18	失真率 Distortion	/		
19	各部 材质	Cone Paper	Rubber Edge+PP injection cone	
		Voice Coil	Kapton+SV	
		Cap	Foam	
20	总重量 Total Weight	/		
	Size: 6.5"	Approve:	Check:	Design:
	試作發行: 2012.09.16	Arthur	John	LIU

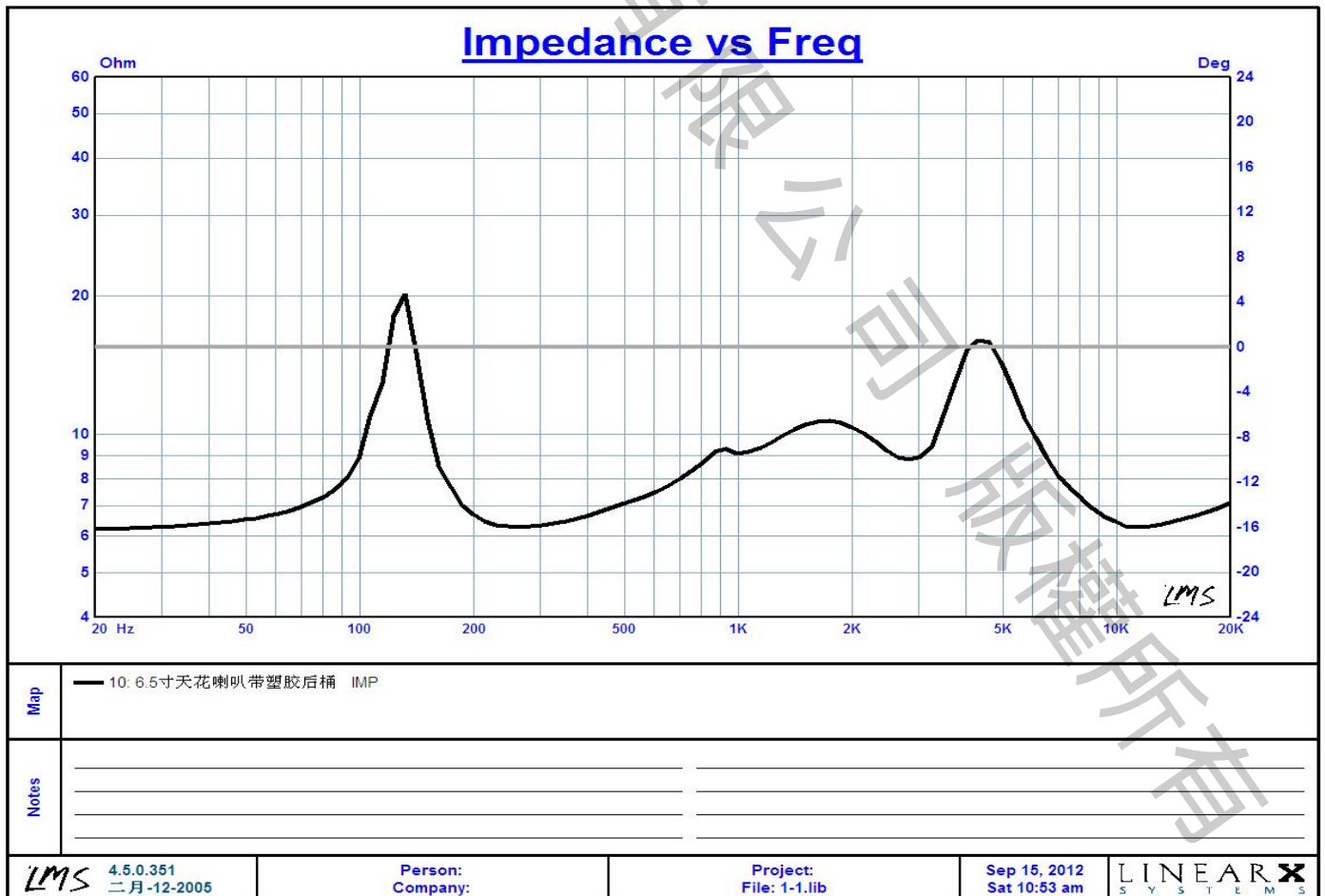
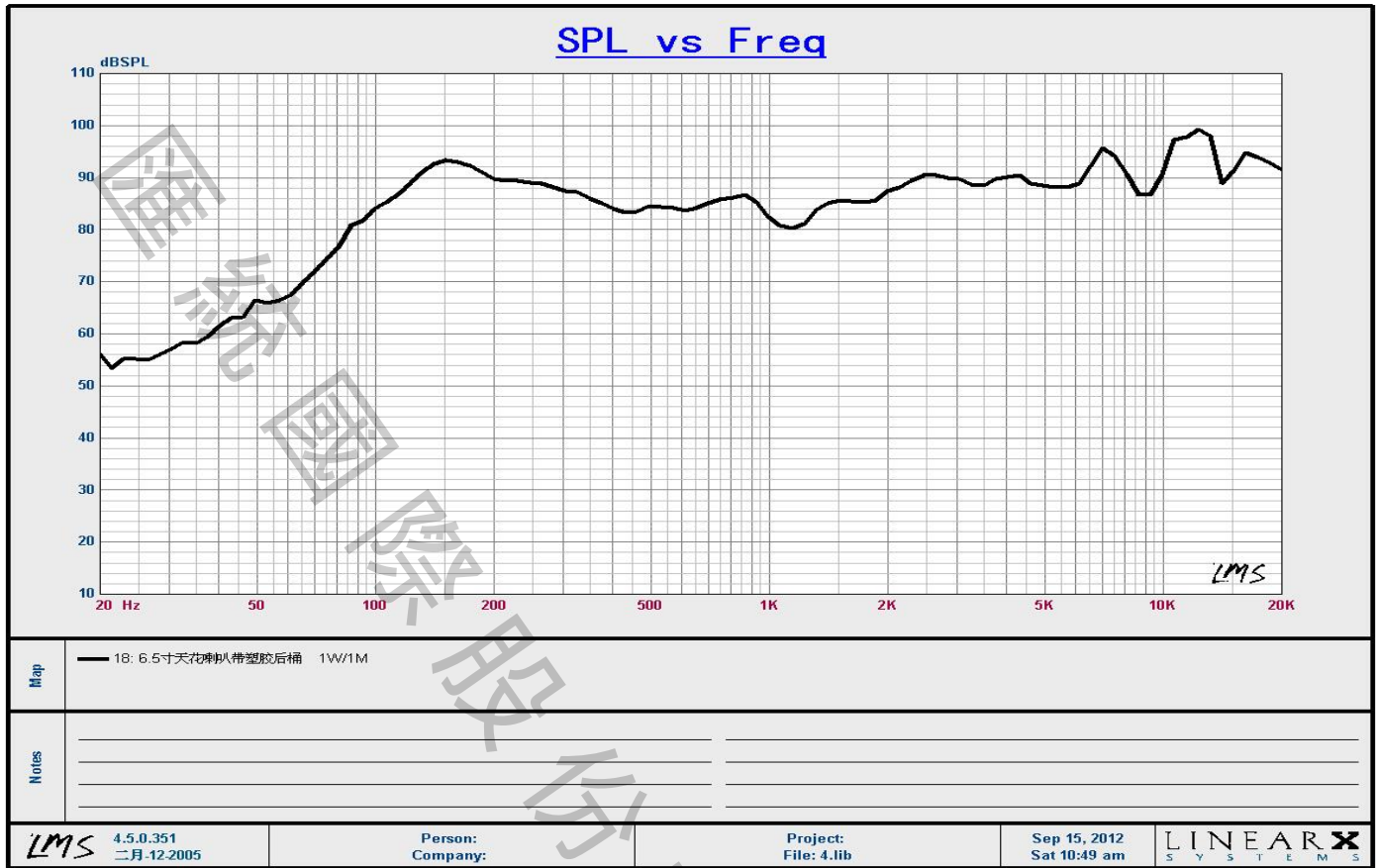

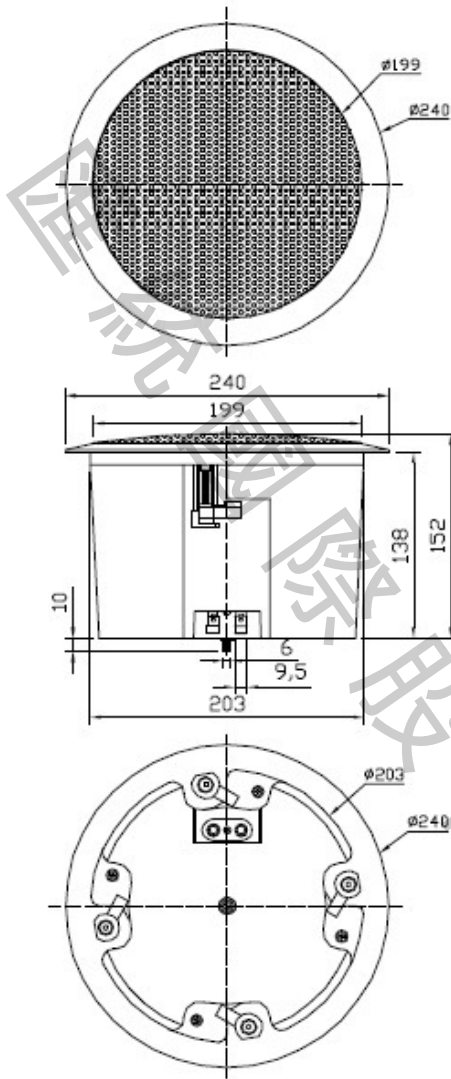

Tolerance:  $\pm 0.5$

Unit:mm